

---

# Chapter 9

# Internet



# Outline

---

## 9.2 – How Internet Works

- Basic Architecture
- Connecting to an ISP
- Internet Today

## 9.3 - Internet Access Technologies

DSL

Cable modems

Fiber to the Home

WiMAX

## 9.4 – Internet Future & Internet Governance

# Who Invented the Internet and Why?

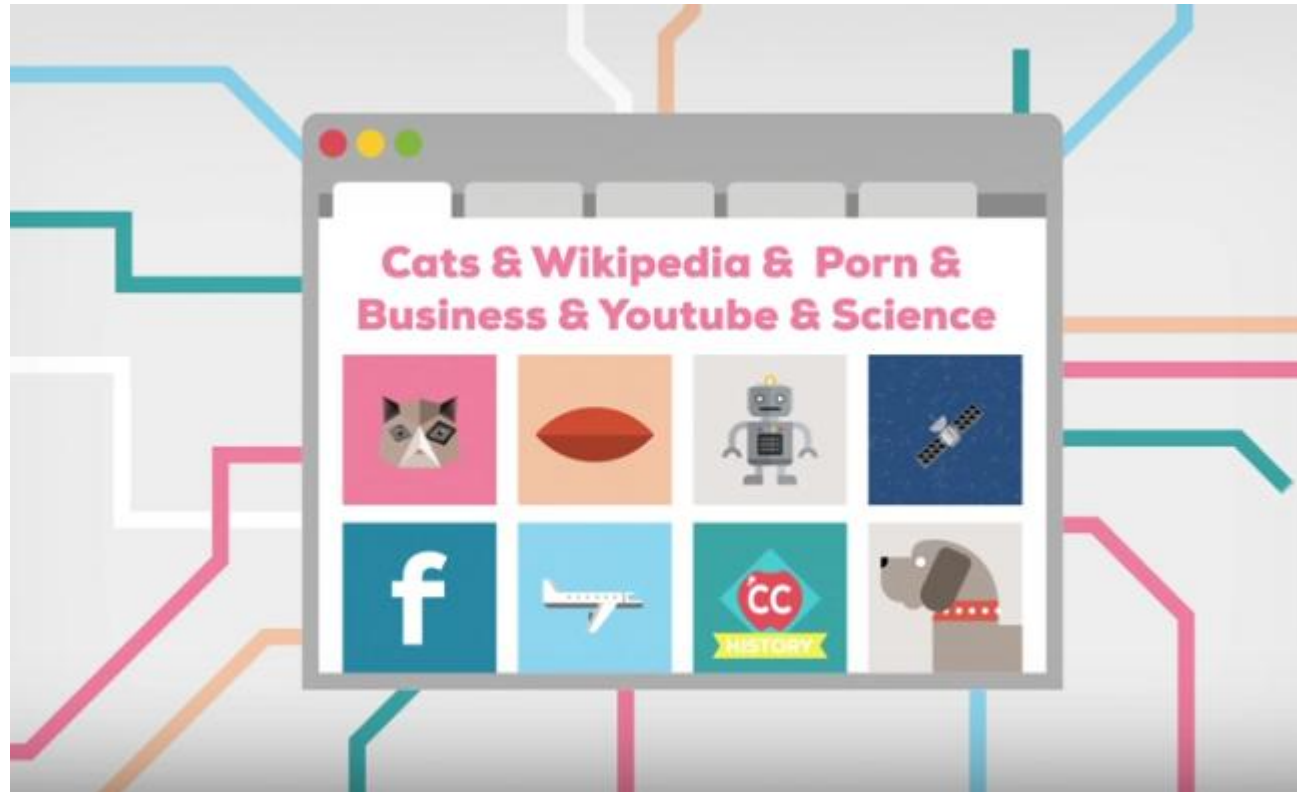

<https://www.youtube.com/watch?v=21eFwbb48sE>

# 9.1 Introduction to the Internet

---

- Network of networks
- Strict Protocols (RFC)
  - To exchange data, these networks must use Internet protocols
  - TCP/IP
- Unrestricted applications and contents
  - Developed freely
- Decentralized (*For the most part...*)

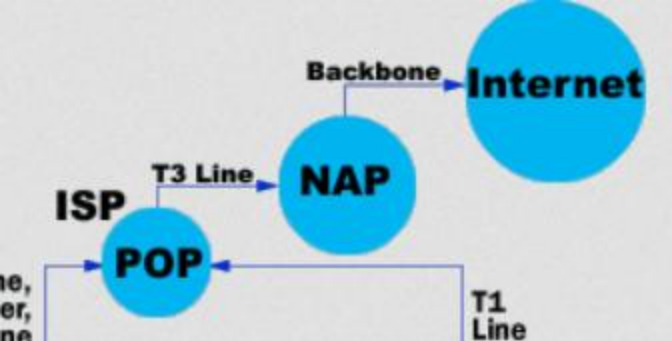

# Internet's Hierarchical Structure

---

- **Tier 1 Internet Service Providers (ISPs)**
  - Provide services to their customers
  - Sell access to tier 2 and 3 ISPs
- **Tier 2 (Regional ISPs)**
  - Connect with tier 1 ISPs
  - Provide services to their customers
  - Sell access to local ISPs
- **Tier 3 ISPs**
  - Connected with tier 1 or 2 ISPs
  - Sell access to individuals

# Internet's Access Points

---

- **Network Access Points (NAPs)**
  - Connect tier 1 ISPs
  - Sometimes large tier 2 and 3 ISPs may also have direct NAP access
    - Indiana University, for example connects directly to Chicago NAP
  - About a dozen U.S.NAPs
  - Run by common carriers, such as Sprint and AT&T
- **Metropolitan Area Exchanges (MAEs)**
  - Connect tier 2 ISPs

# Basic Internet Architecture

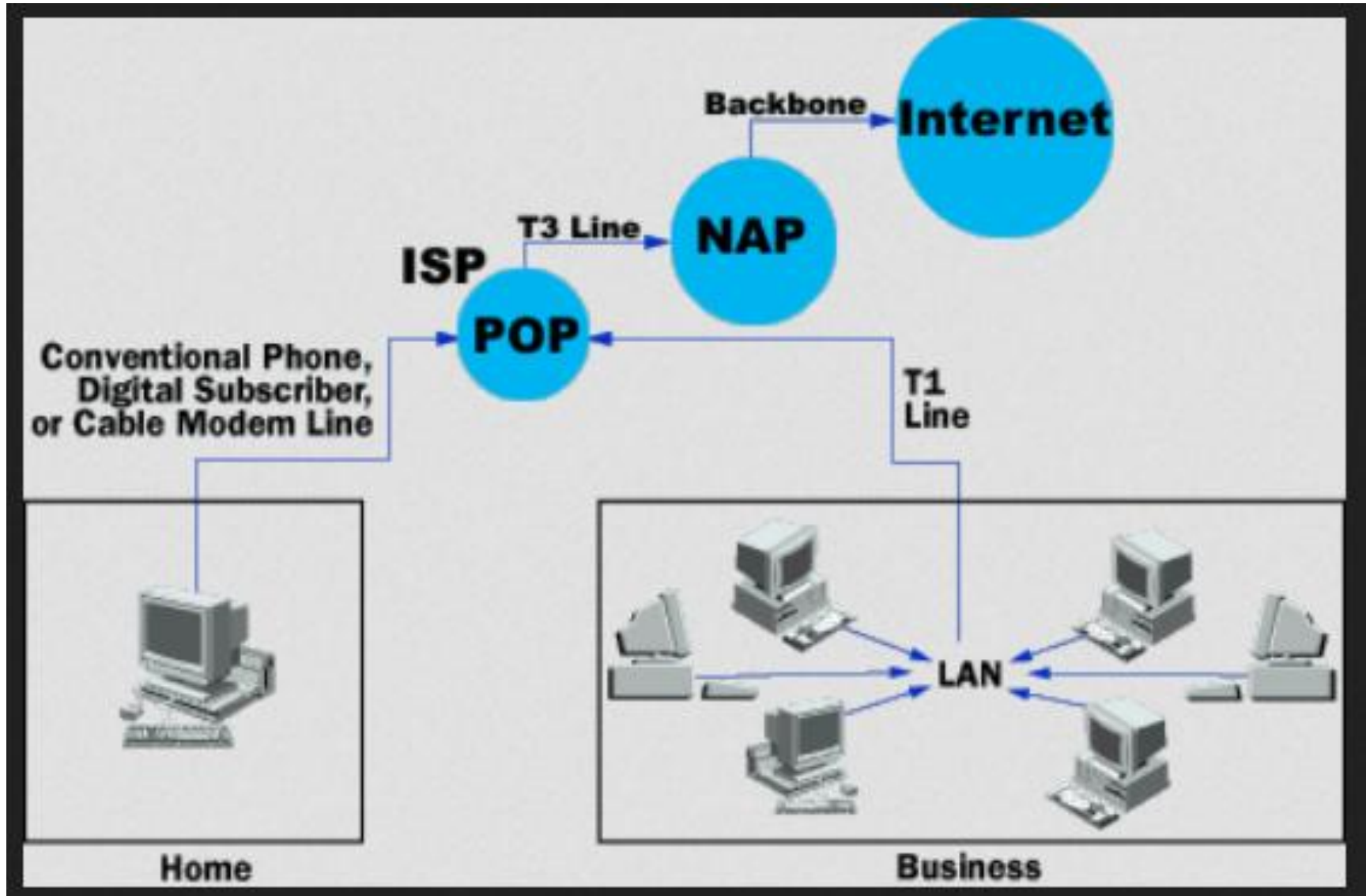

# Basic Internet Architecture

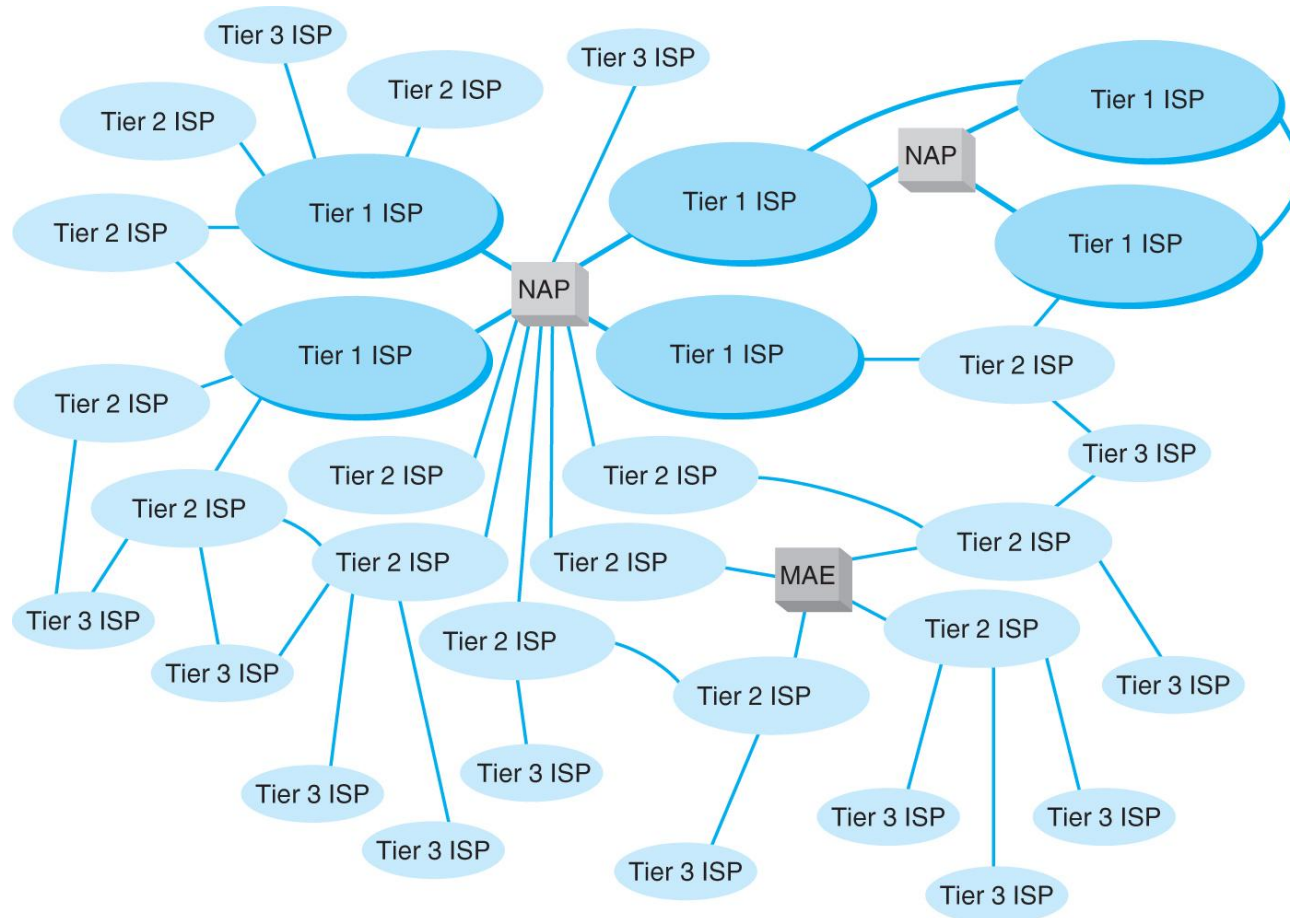



# Packet Exchange Charges

---

- **Peering**
  - ISPs at the same level usually do not charge each other for exchanging messages



- **Higher level ISPs charge lower level ISPs**
- **Tier 3 ISPs charge individuals and corporate users**



# Connecting to an ISP

---

- **Done through ISP's Point of Presence (POP)**
  - Place where ISPs provide service
- **Individual users**
  - Typically cable or DSL
    - Userid and password checked by Remote Access Server (RAS)
    - Once identified and authenticated, user can access Internet
- **Corporate users**
  - Typically access POP using a T-1, T-3 or ATM OC-3 provided by common carrier
    - Cost = ISP charges + circuit charges

# Inside an ISP POP

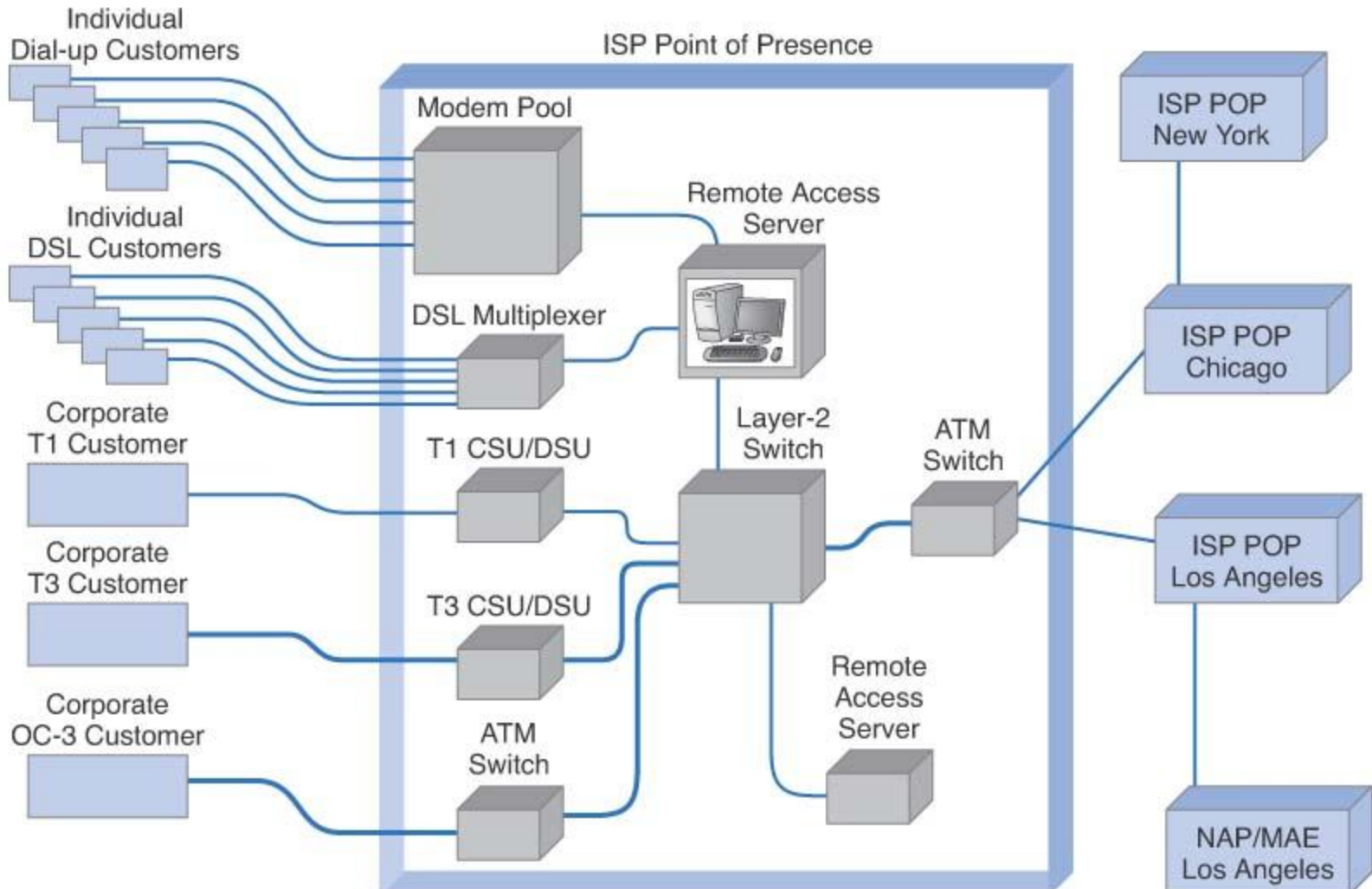

# Internet Exchange Point: Traffic Exchange

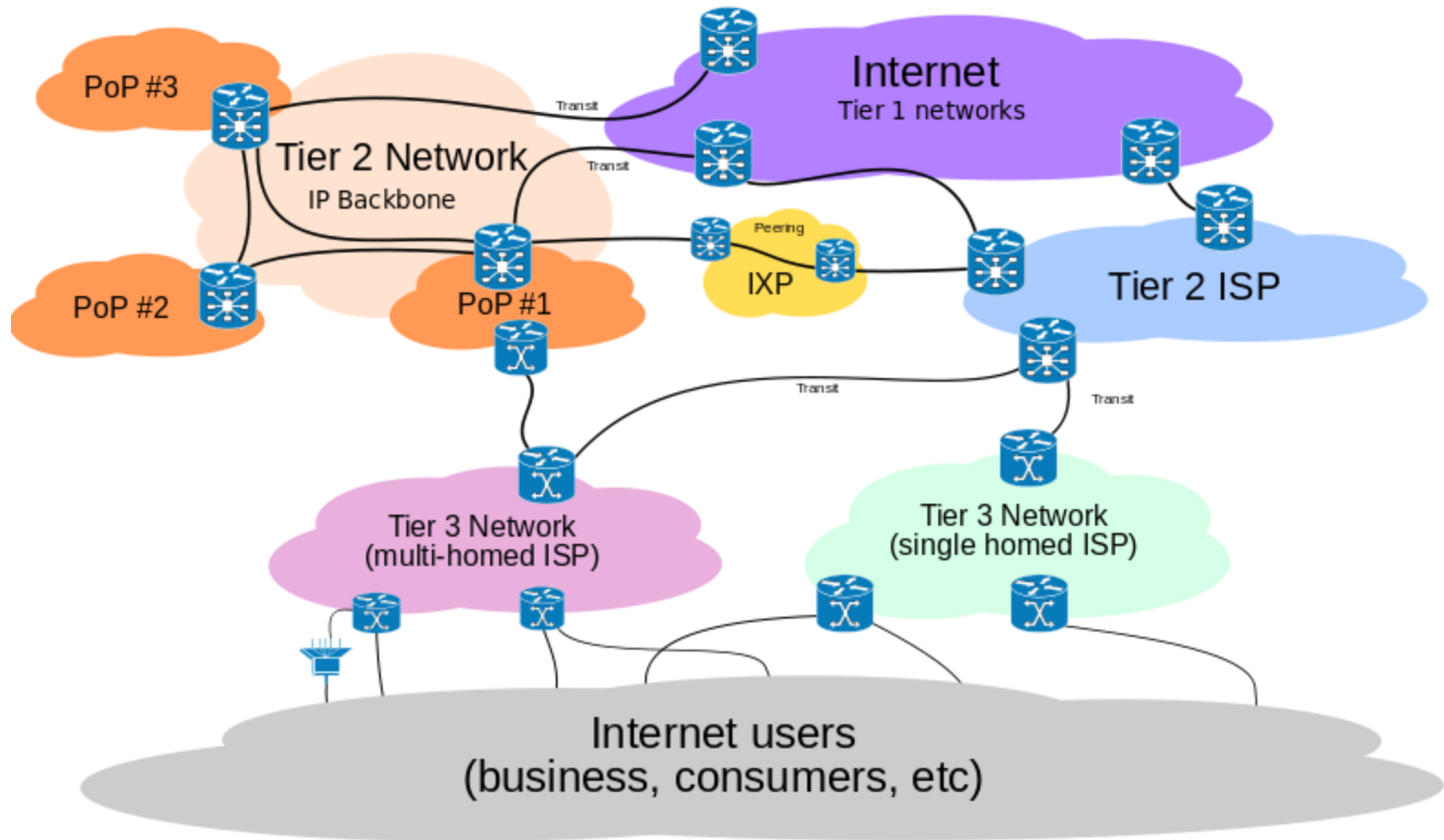

# Internet Backbones

---

- **Backbone circuits for national ISPs**
  - OC-48 and OC-192 (10 Gbps) becoming more common
  - Larger backbones converting to OC-192 (10 Gbps)
  - OC-768 (40 Gbps) and use OC-3072 (160 Gbps) in experiment stage
- **Aggregate Internet traffic**
  - Growing rapidly
  - In 2011, Internet traffic was about 80 Terabits per second (Tbps).
  - NAPs and MAEs becoming bottlenecks
    - Need larger switches
- [www.navigators.com/isp.html](http://www.navigators.com/isp.html)

# Sprint's Internet Backbone

- Tier 1 ISP, Circuits: mostly ATM OC-12; few OC-48 and OC-192

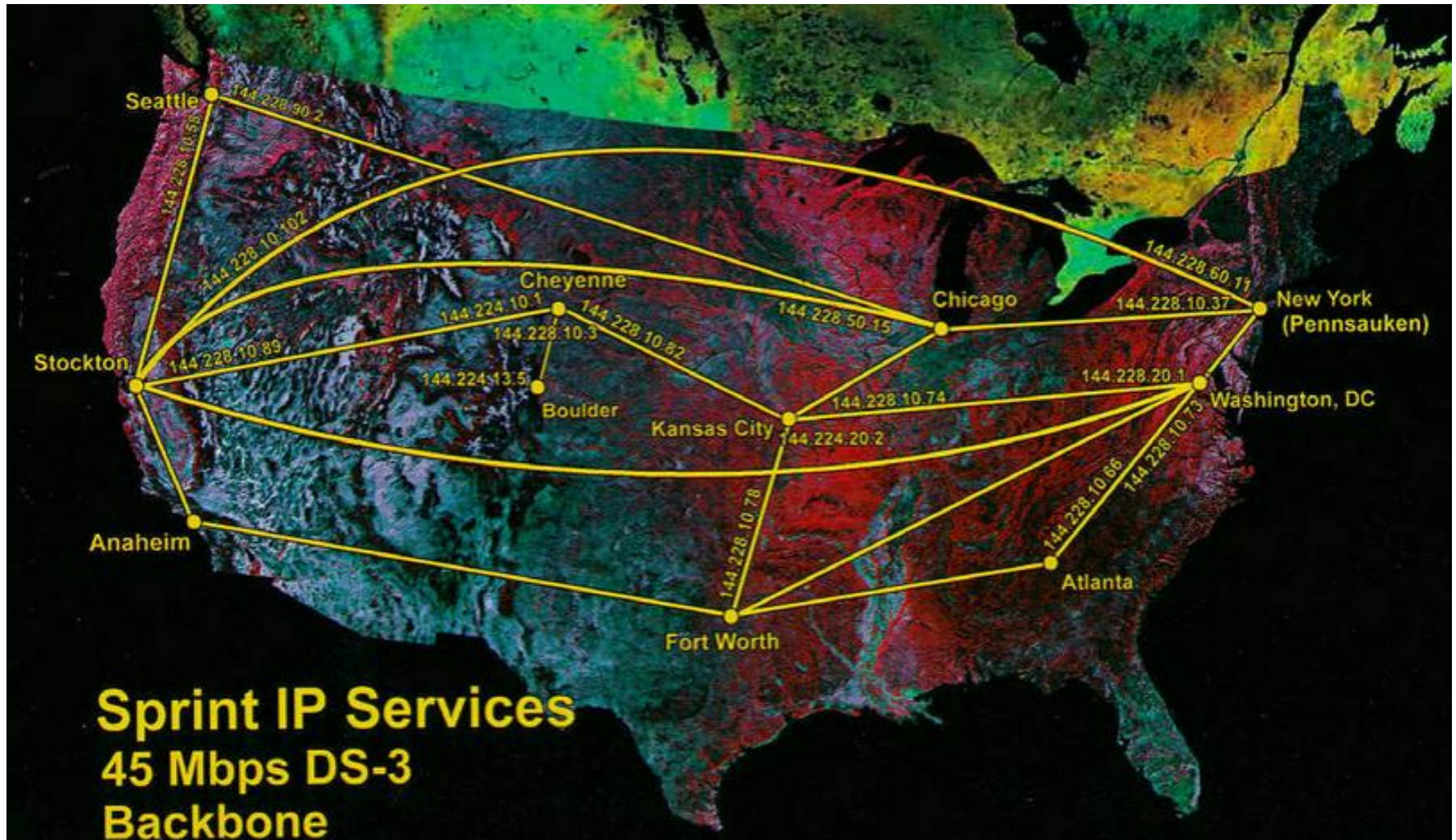

## **9.3 Internet Access Technologies**

---

- **Internet access technologies**
  - **Most methods commonly called “broadband access”**
    - **Doesn’t refer to analog communication, rather refers to high speed**
  - **Digital Subscriber Line (DSL)**
  - **Cable Modems**

# **Digital Subscriber Line (DSL)**

---

- **Point-to-point**
- **High speed data transmission over traditional telephone lines**
  - **Limited capacity due to telephone and switching equipment at the end offices**
  - **Constrained by 4 KHz voice channel**
  - **Much higher bandwidth possible (with new technology based equipment → DSL)**
- **Requires changing telephone equipment rather than rewiring local loop**
- **Not available in all US locations**
  - **More wide spread in Asia, Europe and Canada**



# **Digital Subscriber Line (DSL)**

---

- **Customer premises equipment (CPE) installed at customer location**
  - **Contains line splitter**
    - **Directs traffic to phone network and DSL modem (aka DSL router)**
- **Local loops connect to the MDF**
  - **MDF splits neighborhood voice and data traffic to phone network and DSLAM (DSL access multiplexer)**

# DSL Architecture

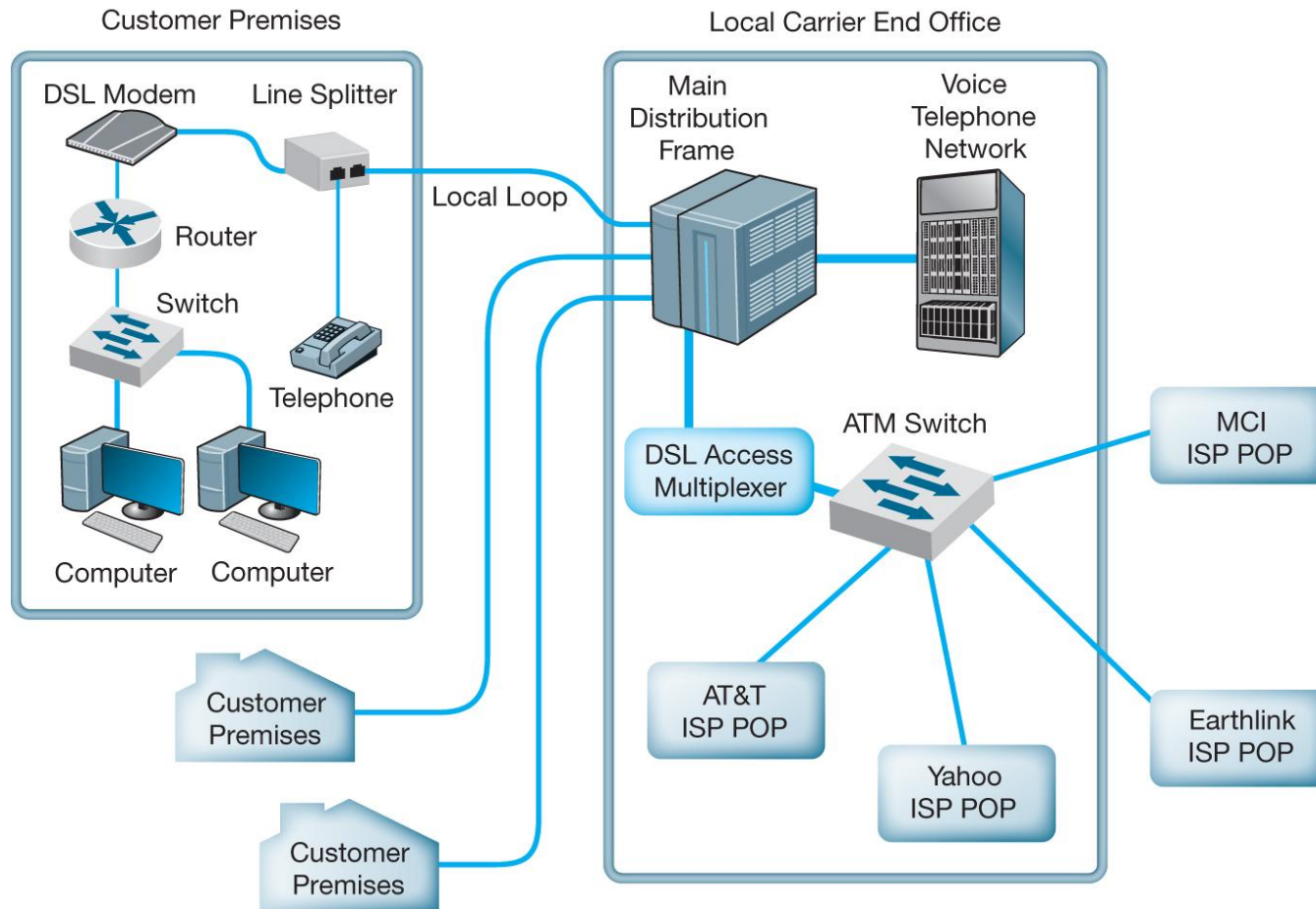

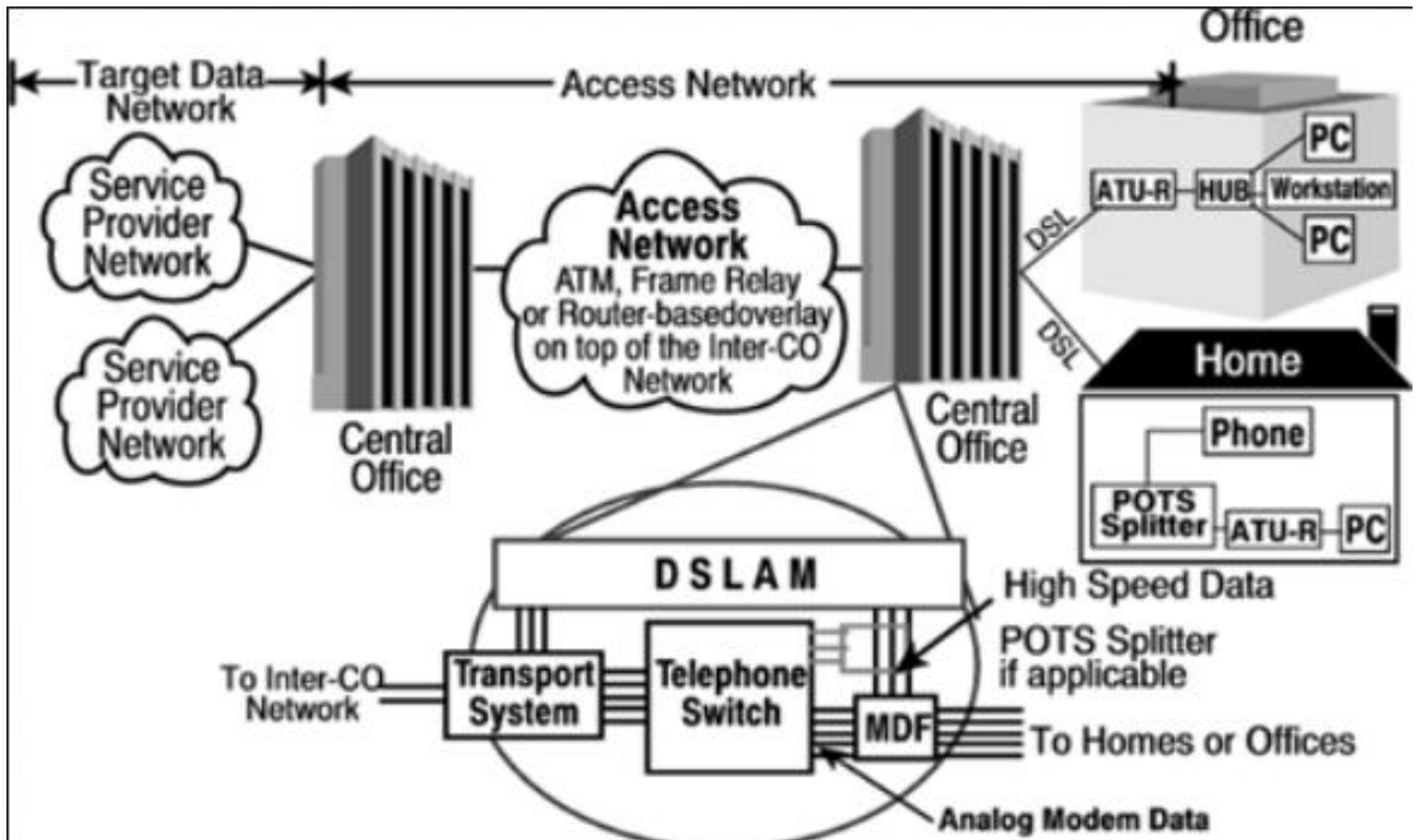

# Types of DSL

---

- **Asymmetric DSL (ADSL), most common**
  - **Uses three FDM channels**
    - **4 KHz analog voice channel**
    - **Simplex data channel for downstream traffic**
    - **Slower duplex data channel for Upstream traffic**
  - **Size of digital channels**
    - **Depends on the distance (CPE-Office) (up to 18,000 ft)**

# DSL Data Rates

---

Maximum Downstream Rate	Maximum Upstream Rate
1.5 Mbps	384 Kbps
6 Mbps	640 Kbps
12 Mbps	1.5 Mbps
18 Mbps	1.5 Mbps
24 Mbps	3 Mbps

# Cable Modems

---

- **Hybrid fiber coax**
- **Data Over Cable Service Interface Specifications (DOCSIS)**
  - Most common cable modem protocol
  - Not a formal standard
- **Speeds vary (depends on the quality of cable plant)**
  - In theory: downstream: 150 Mbps; upstream: 100 Mbps
  - Typical: downstream: 1-10 Mbps; upstream 0.25 – 1 Mbps

# **Cable Modem Architecture (1 of 2)**

---

- **Similar to DSL (one main difference):**
  - DSL: point-to-point
  - Cable modems: shared multipoint circuit
    - All messages on the circuit heard by all computers on the circuit → security issue
    - 300 – 1000 customers per cable segment
- **Type of equipment used**
  - Cable Modem Termination System (CMTS)
    - Used for upstream traffic only
    - Converts data from DOCSIS to Internet protocols
  - Fiber Node with an Optical Electrical (OE) converter
  - Combiner (for downstream traffic only)
    - Combines Internet traffic with TV video traffic

# Basic Cable Modem Architecture (2 of 2)

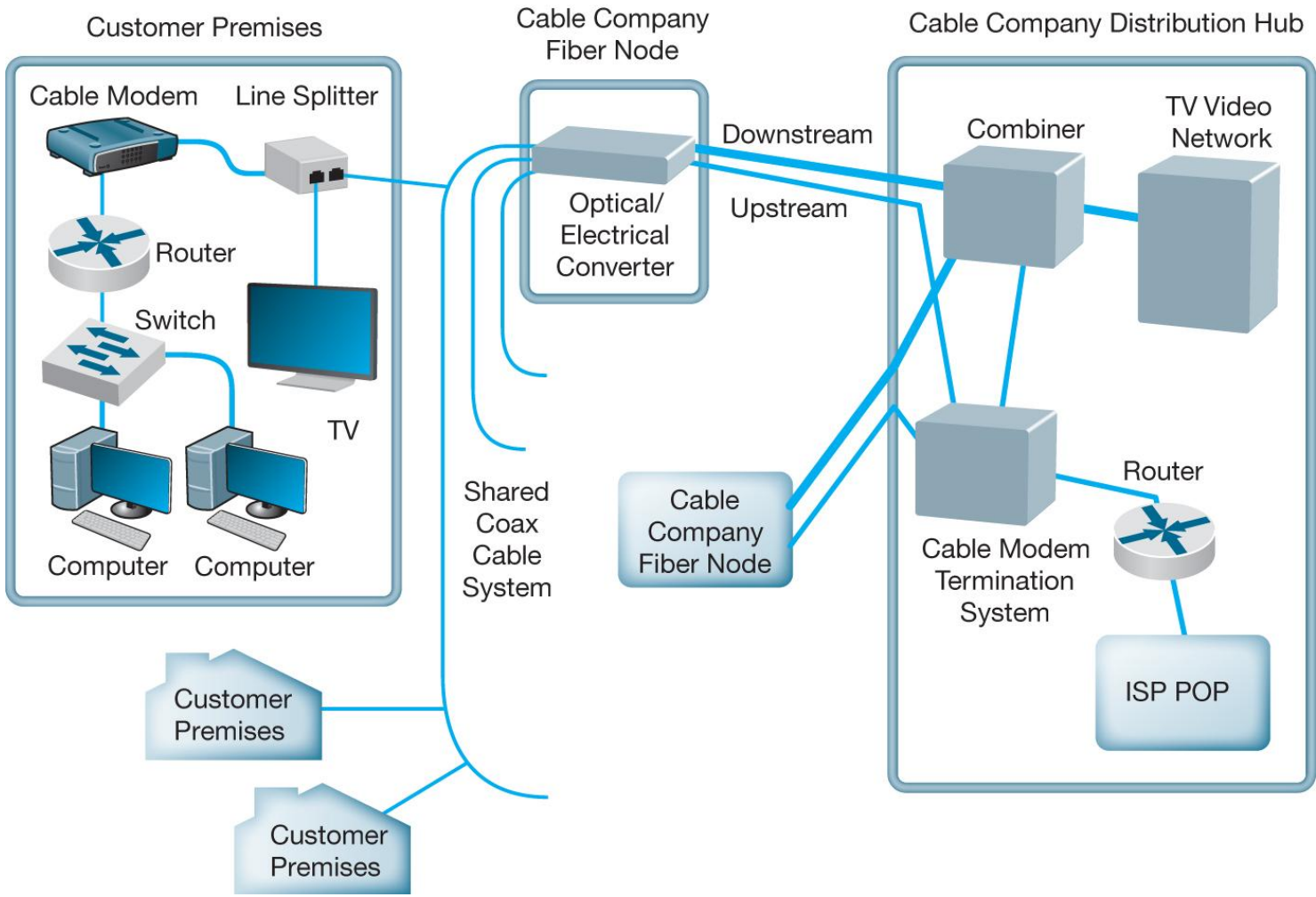



# Google Fiber

## GOOGLE FIBER

### SPEED

Up to 1,000 Mbps; Kansas City demo reached a top speed of 938 Mbps

### PRICING

Internet and TV, \$120/mo;  
Internet-only, \$70/mo;  
Free Internet with one-time construction fee (\$300)

### AVAIL

Kansas City, Mo. & Kan.;  
Austin, Texas (2014)

## CABLE

### SPEED

Standard is 15 Mbps; Time Warner Cable can offer max speeds of 50 Mbps

### PRICING

15 Mbps Internet and TV, \$79.99/mo for 12 mos;  
50 Mbps Internet & Digital TV, \$99.99/mo for 12 mos

### AVAIL

Serves 12M video subs;  
10.9M Internet subs



Fiber Bunny

# **WiMAX (802.16)**

---

- **Wireless standard developed to connect to Ethernet LANs**
- **Can be fixed or mobile wireless**
  - **Some vendors refer to it as 4G**
  - **ISPs beginning to provide**
- **PCF media access is used (controlled)**
- **2.3, 2.5, and 3.5 GHz ranges**
- **Max range is 3-10 miles**
- **Common data rate is 40 Mbps**
- **4G (Sprint is retiring WiMAX)**

# HOW WiMAX WORKS

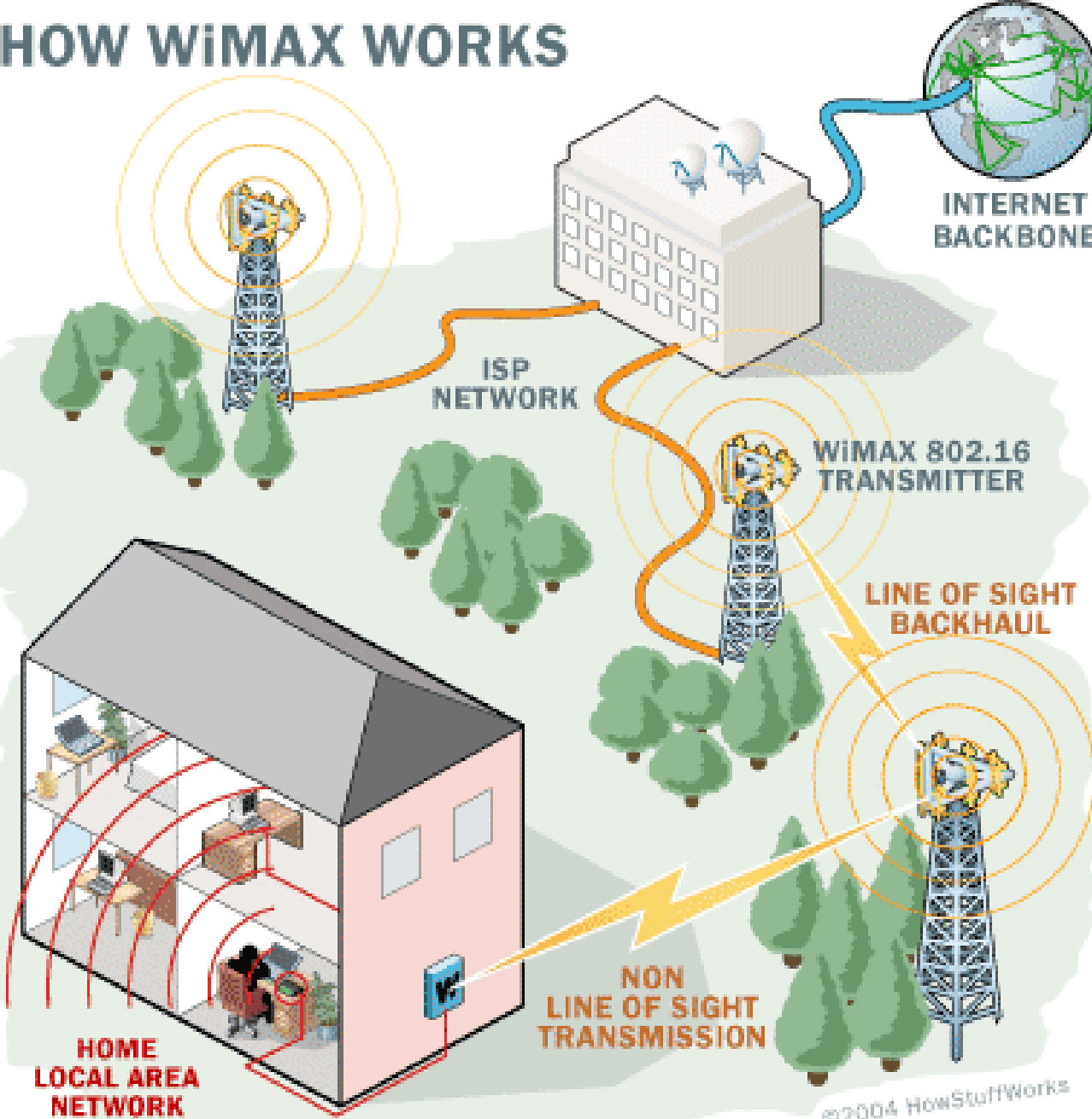

**WiMax a family of technologies much like 802.11.**

---

**Many envision a future with both Wi-Fi and WiMax.**

**Laptops and Smart phones connect to Wi-Fi networks in home and office locations where Wi-Fi is available.**

**If Wi-Fi not available and user has subscribed to WiMax, then laptop or smart phone will connect to WiMax network.**

---

©2004 HowStuffWorks

# Comparing WiFi and WiMax

---

## WiMAX

- Relatively, long range system, covering many kilometres,
- Uses licensed or unlicensed spectrum to deliver connection to a network, in most cases the Internet.
- **Wi-Fi**
  - Uses unlicensed spectrum to provide access to a local network.
  - More popular in end user devices.

# Internet Governance

---

- **No one organization operates the Internet**
- **Closest: Internet Society (ISOC)**
  - **Over 175 organizational and 8000 individual members in over 100 countries**
    - **Open membership professional society**
  - **Mission: “Open development, evolution and use of the Internet for the benefit of the people in the world.”**
  - **ISOC areas**
    - **Public policy:**
    - **Education**
    - **Standards**

# **Selected ISOC Standard Bodies**

---

- **Internet Engineering Task Force (IETF)**
  - Concerned with evolution of Internet architecture and smooth operation of Internet
  - Oversees Request For Comments (RFC): (Internet standards)
- **Internet Architecture Board (IAB)**
  - Provides strategic architectural oversight, guidance

# **Internet Corporation for Assigned Names and Numbers (ICANN)**

---

- **Nonprofit private organization, created ('98) to oversee Internet related tasks previously performed directly on behalf of US government by other organizations notably Internet Assigned Numbers Authority (IANA) which ICANN now operates.**
- **Responsible for coordination of IP 4 and 6 and for management of top level domain name space (DNS root zone).**

## ICANN Evolving

- Fadi Chehade: First thing is that it is important to know the US government fulfilled their promise, and the promise was that at some point, when the ICANN community is ready, they would step back and be equal to everybody at the table. They just announced they intended to do it 15 years ago.
- They (Commerce Dept) continued their job, but they said that they planned to basically stop what they do on some conditions. Their condition is that the community come back to them with a proposal. They will review the proposal. If the proposal meets their principles, then they will sit aside and be equal to everybody.
- What ICANN does to the registry of the Internet does not change. What changed is who ensures we are doing our job, but not the job. It's very important to have that distinction.
- Our roles are not changed. It's that who checks if ICANN is really doing its job changed. .... We simply need a new mechanism that is transparent, that is open, that keeps ICANN's implementation accountable to everybody.
- Our job continues. It's just a question of who watches over our work.



# Future Internet Features

---

- **Access via Gigapops, similar to NAPs**
  - Operate at very high speeds (10 Gbps) using SONET, ATM and IPv6 protocols
- **IPv6 rather than IPv4**
- **New protocol development focuses on issues like**
  - Quality of Service
  - Multicasting
- **New applications include**
  - Tele-immersion
  - Videoconferencing
- **Cloud Computing**

# 9.5 Implications

---

- **Concern about traffic (slow)**
  - New fiber based circuits deployment along with Next Generation Internet
- **Many new broadband technologies for high speed Internet access**
  - Simple to move large amount of data into most homes and business → richer multimedia apps
- **Which access technology to dominate?**
- **Wireless communications becoming pervasive...**

# Questions?

---